

ADVANCE ADAPTERS INC.

P.O. Box 247, 4320 Aerotech Center Way
Paso Robles, CA 93447

Telephone: (800) 350-2223 Fax: (805) 238-4201

P/N: 50-6306

New Item: (11/93)

PAGE 1 OF 3

Page Rev. Date: 01-26-09

GM TH350 AUTO TO JEEP N/P T/C/21 SPLINE REPLACING PEUGEOT TRANSMISSION

KIT CONSISTS OF:

| No. | Qty | Part No. | Description |
|-----|--------|----------|--|
| 1. | 1 | 51-6300 | CASTING (Ref: 711163) (Assembled by AA) |
| 2. | 1 | 52-6300 | SPUD SHAFT (21 Splines) (Assembled by AA) |
| 3. | 1 Pack | 714201 | BOLTPACK (50-6300) |
| 4. | 1 | 716308 | BEARING (#6209) (Assembled by AA) |
| 5. | 1 | 716450 | SNAP RING (Assembled by AA) |
| 6. | 1 | 716456 | SNAP RING (T/A #N5000-334) (Assembled by AA) |
| 7. | 1 | 716511 | "O" RING |
| 8. | 1 | 716517 | GASKET |
| 9. | 1 | 716738 | NATIONAL SEAL (#473459) DUAL LIP |
| 10. | 6 | 723711 | STUD BOLT 3/8"-16x2" LG. |
| 11. | 1 | JP001 | JEEP INSTRUCTION MANUAL |

OPTIONAL ITEMS:

| Qty | Part No. | Description |
|-----|----------|----------------------|
| 1 | 716008 | CROSSMBR. MOUNT |
| 1 | 715523 | T/C SHIFTER BRKT. |

NOTE:

Peugeot transmissions have a long output shaft stickout of a 1/2". This measurement is taken from the back of the transmission adapter to the end of the output shaft. This adapter assembly is a copy of the stock Peugeot stickout length. If your stock transmission has a flush output shaft stickout, you will need to shorten the spud shaft in this kit to match the stock transmissions stickout. If you have questions on this, please call before cutting.

This adapter kit includes a new seal that must be installed into the front side of the New Process transfer case. The seal will prevent fluid from mingling between the two gear boxes. Since we have eliminated the tailhousing seal that was originally in the previous adapter, a gasket must be used between the transfer case and the adapter housing.

SPECIAL NOTE: The components packaged in this kit have been assembled and machined for specific type of conversions. Modifications to any of the components will void any possible warranty or return privileges. If you do not fully understand modifications or changes that will be required to complete your conversion, we strongly recommend that you contact our sales department for more information. This instruction sheet is only to be used for the assembly of Advance Adapter components. We recommend that a service manual pertaining to your vehicle be obtained for specific torque values, wiring diagrams and other related equipment. These manuals are normally available at automotive dealerships and parts stores.

ADVANCE ADAPTERS INC.

P.O. Box 247, 4320 Aerotech Center Way
Paso Robles, CA 93447

Telephone: (800) 350-2223 Fax: (805) 238-4201

P/N: 50-6306

New Item: (11/93)

PAGE 2 OF 3

Page Rev. Date: 03-08-01

GM TH350 AUTO TO JEEP N/P T/C/21 SPLINE REPLACING PEUGEOT TRANSMISSION

GM TH350 3 SPEED AUTOMATIC

The General Motors TH350 has a case length of 21-1/2", 13 bolts holding the oil pan in position and is available in two different engine to transmission bolt patterns. The case is available with a Chevy bolt pattern that has the top two holes 8-1/4" apart or a Buick bolt pattern that has the top two holes 7" apart. The rear side of the transmission case should have a square bolt pattern that uses 4 bolts. There are several various lengths of output shafts that these transmissions have been furnished with and you must make sure the proper shaft has been installed into the transmission for use with the Advance Adapter transfer case kit. We standardize our kits on the GM 4 wheel drive output shafts that were used in vehicles 1973-1979. All TH350 output shafts will have 27 splines. The speedometer gear is normally located in the tailhousing, but when adapting it to the transfer case, the location will change to the back side of the transfer case. The rear transmission support is located in the main case just forward of the tailhousing connection. This can be used for supporting the crossmember on some installations, but most of the Advance Adapter kits provide support on the new adapter housing.

When installing the new transfer case adapter, make sure that the coupler and the output shaft do not bottom out. We have found on occasion that a transmission output shaft may be slightly longer than we have allowed for; and when coupling into our new spud shaft, we find a small amount of interference. The adapter housing and spud shaft must be assembled to the back of the transmission without interference. **DO NOT FORCE THE NEW TAILHOUSING ONTO THE TRANSMISSION.** If assistance is needed, please feel free to call the number listed above.

When assembling the adapter housing to the transmission case, we have provided you with a new square-type "O" ring seal to prevent fluid leakage. This seal is a stock GM item that is used on all TH350 installations. Use silicone sealant on both surfaces of the transfer case gasket, and Loctite all fasteners.

All installations will require the use of a transmission cooler. The cooler can be either installed in the radiator or a remote location is acceptable. The transmission shift control can either be a Hurst floor mounted type shifter or sometimes the existing column shift can be modified on certain applications.

CAUTION!

Gasket positioning between the transfer case and new Advance Adapters housing is **CRITICAL**. If you fail to get the gasket in the proper location, oil seepage will occur. See photo for correct positioning.



SPECIAL NOTE: The components packaged in this kit have been assembled and machined for specific type of conversions. Modifications to any of the components will void any possible warranty or return privileges. If you do not fully understand modifications or changes that will be required to complete your conversion, we strongly recommend that you contact our sales department for more information. This instruction sheet is only to be used for the assembly of Advance Adapter components. We recommend that a service manual pertaining to your vehicle be obtained for specific torque values, wiring diagrams and other related equipment. These manuals are normally available at automotive dealerships and parts stores.

ADVANCE ADAPTERS INC.

P.O. Box 247, 4320 Aerotech Center Way
Paso Robles, CA 93447

Telephone: (800) 350-2223 Fax: (805) 238-4201

P/N: 50-6306

New Item: (11/93)

PAGE 3 OF 3

Page Rev. Date: 03-13-01

GM TH350 AUTO TO JEEP N/P T/C/21 SPLINE REPLACING PEUGEOT TRANSMISSION

INSTALLATION:

1. This kit comes pre-assembled with the bearing, snap rings, and spud shaft installed in the casting. The bearing and spud shaft are a press fit. The spud shaft is pressed to the bearing and the snap ring installed to retain the spud shaft properly. The bearing and spud shaft assembly are also a press fit into the adapter housing. The bearing and spud shaft are pressed into the casting. This assembly is retained with the provided snap ring.
2. Install the o-ring on the casting and use a small amount of silicone to provide a good seal. Bolt the adapter assembly to the TH350 transmission.
3. Using a thin film of silicone on both sides of the transfer case gasket, install the transfer case and gasket to the adapter assembly. The studs in the Dana 300 should locate the transfer case in the proper rotation, and the Dana 300 front alignment retainer should properly index the transfer case.
4. The Advance Adapters crossmember mount will bolt to the bottom of the adapter casting. Mark and drill new holes in the skid plate to secure the transmission assembly to the skid plate.
5. Make sure all fasteners are secured and Loctite is used.

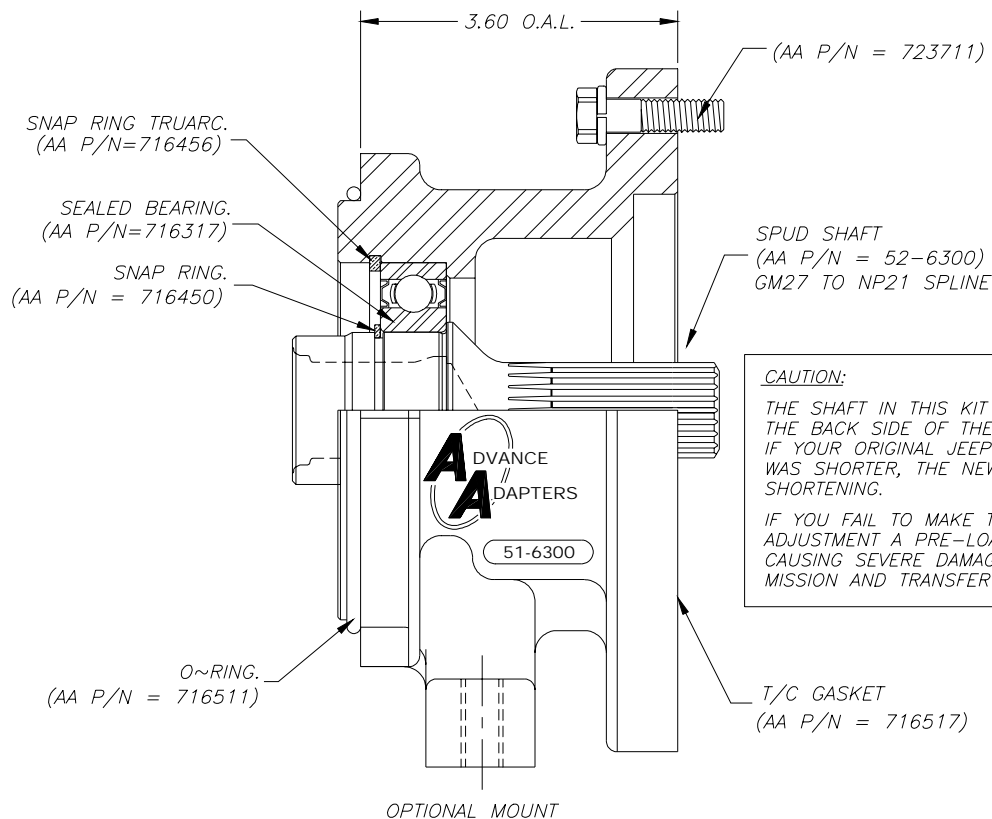

SPECIAL NOTE: The components packaged in this kit have been assembled and machined for specific type of conversions. Modifications to any of the components will void any possible warranty or return privileges. If you do not fully understand modifications or changes that will be required to complete your conversion, we strongly recommend that you contact our sales department for more information. This instruction sheet is only to be used for the assembly of Advance Adapter components. We recommend that a service manual pertaining to your vehicle be obtained for specific torque values, wiring diagrams and other related equipment. These manuals are normally available at automotive dealerships and parts stores.