



TEL: 1-866-XANATOS

INSTALLATION INSTRUCTIONS

**PART # 9B083801SS/9B083801A
SIDE BAR FOR JEEP WRANGLER 4 DOOR 07-11**

Parts List

1	Driver/Left Sidebar	6	10mm ID x 34mm OD x 3mm Flat Washers
1	Passenger/Right Sidebar	2	8mm x 35mm Hex Bolts
1	Driver/Left Front Mounting Bracket (medium length)	12	8mm x 25mm Hex Bolts
1	Passenger/Right Front Mounting Bracket (medium length)	14	8mm Lock Washers
1	Driver/Left Center Mounting Bracket (long)	12	8mm x 24mm OD x 2mm Flat Washers
1	Passenger/Right Center Mounting Bracket (long)	2	8mm x 28mm OD x 3mm Large Flat Washers
1	Driver/Left Rear Mounting Bracket (short)	12	6mm x 25mm Button Head Bolts
1	Passenger/Right Rear Mounting Bracket (short)	24	6mm ID x 18mm OD x 1.6mm Flat Washers
6	10mm Nut Plates	12	6mm Nylon Lock Nuts
6	10mm x 35mm Hex Bolts	1	4mm Allen Wrench
6	10mm Lock Washers		

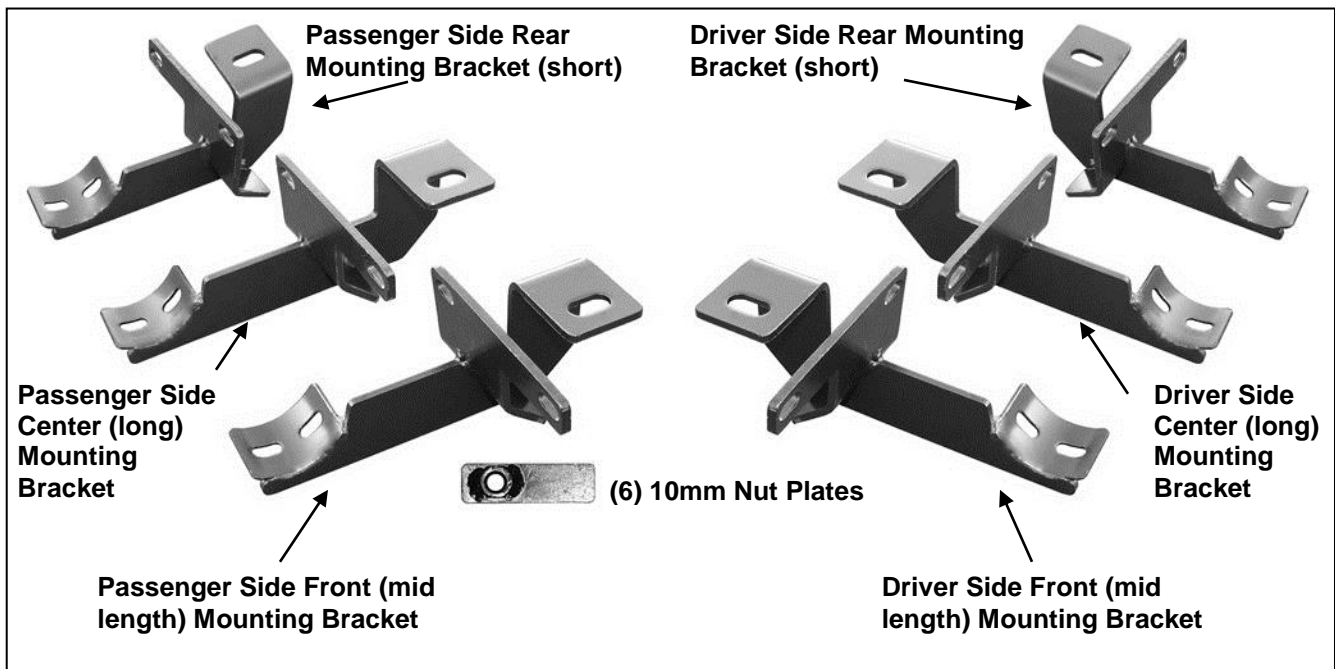

PROCEDURE:

- REMOVE CONTENTS FROM BOX. VERIFY ALL PARTS ARE PRESENT. READ INSTRUCTIONS CAREFULLY BEFORE STARTING INSTALLATION. FACTORY INSTALLED "ROCK RAILS," SIDE STEPS OR RUNNING BOARDS MUST BE REMOVED.**
- Starting at the passenger side front, **(Figure 1)**, select the mid-length front Mounting Bracket, **(Figure 2B)**, and line up the (2) holes in the mounting tab on the Bracket with the (2) factory holes in the pinch weld. Bolt the Bracket to the back of the pinch weld with the supplied (2) 6mm x 25mm Button Head Bolts, (4) 6mm Flat Washers and (2) 6mm Nylon Lock Nuts, **(Figure 2A)**. Do not tighten hardware at this time.
- Insert (1) 10mm Nut Plate up and into the square hole in the frame panel with the welded nut facing up, **(Figure 2A)**. Line up the nut on the Nut Plate with the hole in the Bracket. Bolt the Bracket to the Nut Plate with (1) 10mm x 35mm Hex Bolt, (1) 10mm Lock Washer and (1) 10mm Flat Washer, **(Figures 3A & 4A)**. Repeat **Steps 2 - 3** to install the longer Passenger Side Center Mounting Bracket, **(Figures 3A & B)**.
- Moving to the rear mounting location, remove any insulation covering the 8mm threaded hole in the floor panel. Line up the mounting tab on the short rear Mounting Bracket with the (2) holes in the pinch weld and bolt the Bracket in place as described in **Steps 2 - 3**. Bolt the Bracket to the threaded hole with (1) 8mm x 35mm Hex Bolt, (1) 8mm Lock Washer and (1) 8mm x 28mm OD x 3mm Large Fender Washer, **(Figure 4A)**.

IMPORTANT NOTE! On a few 2010-11 vehicles, the factory has eliminated the threaded hole required for the short rear Mounting Bracket installation. In those instances, insert (1) 10mm Nut Plate into the factory hole in the floor panel, move the plate so that the nut is centered over the hole and attach the Mounting Bracket as described in **Steps 2 - 3, (Figures 1 & 2A)**. Two extra Nut Plates and appropriate hardware have been provided.

5. Once all three Mounting Brackets are securely in position, place the Sidebar onto the Mounting Brackets and secure it with the included (6) 8mm x 25mm Hex Bolts, (6) 8mm Lock Washers and (6) 8mm Flat Washers, **(Figure 5)**. Snug all hardware but do not tighten at this time.
6. Adjust and level the Sidebar and tighten all hardware.
7. Repeat **Steps 2 - 6** for driver/left Sidebar installation.
8. Do periodic inspections to the installation to make sure that all hardware is secure and tight.

To protect your investment, wax this product after installing. Regular waxing is recommended to add a protective layer over the finish. Do not use any type of polish or wax that may contain abrasives that could damage the finish.

For stainless steel: Aluminum polish may be used to polish small scratches and scuffs on the finish. Mild soap may be used also to clean the Sidebar.

For gloss black finishes: Mild soap may be used to clean Sidebar.

Passenger Side Installation Pictured

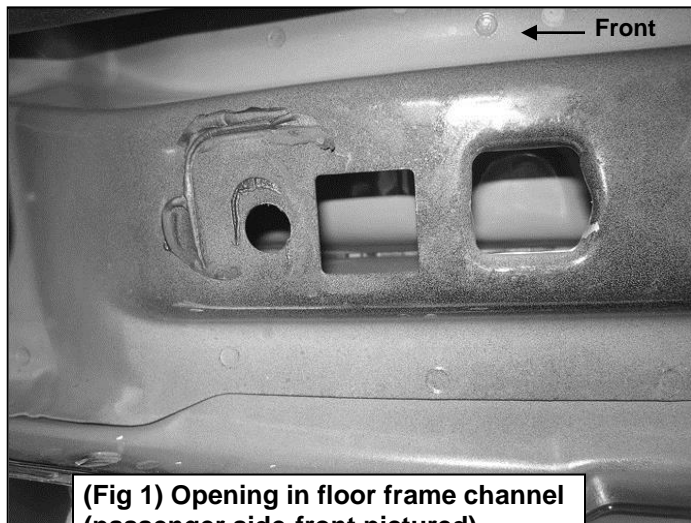

Insert 10mm Nut Plate into opening and line up nut with mounting hole on Bracket

- (2) 6mm x 25mm Button Head Bolts
- (4) 6mm Flat Washers
- (2) 6mm Nylon Lock Nuts

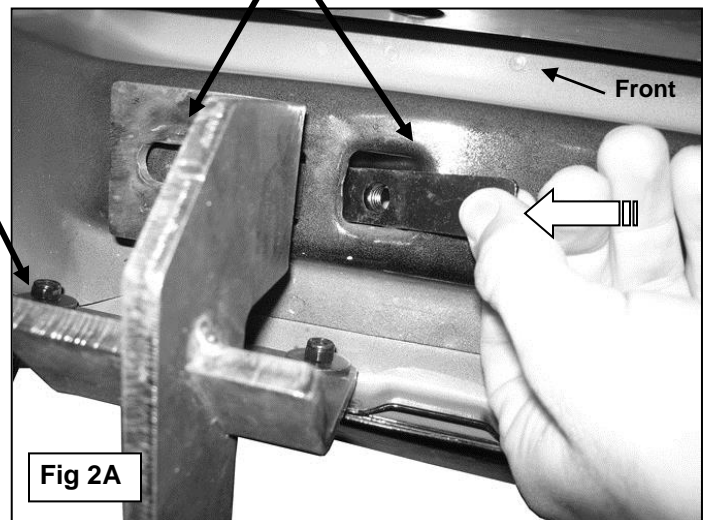
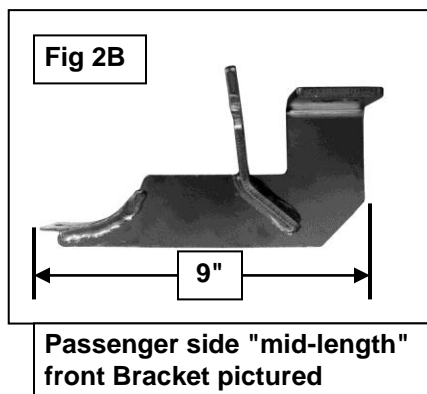

Passenger Side Installation Pictured

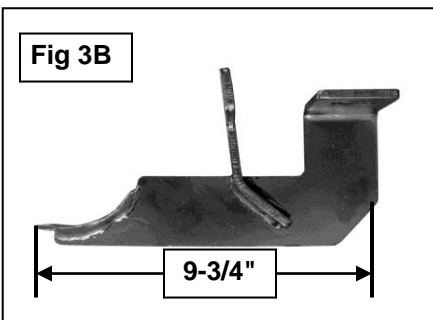
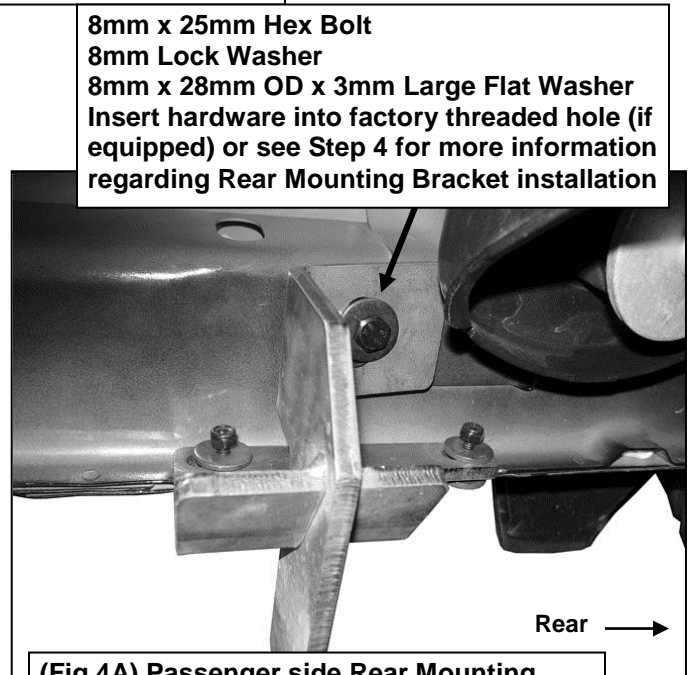
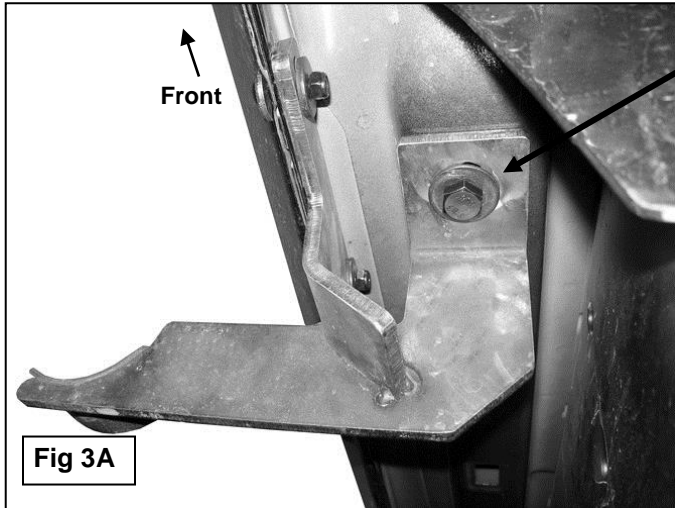

Passenger side "long" center Bracket pictured

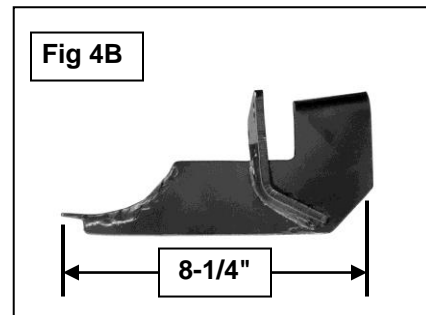

Passenger side "short" rear Bracket pictured

