

ADVANCE ADAPTERS, INC.

P.O. Box 247, 4320 Aerotech Center Way
Paso Robles, CA 93447
Telephone: (800) 350-2223 Fax: (805) 238-4201

P/N: 50-0434

New Item: (01/07)
PAGE: 1 OF 4
Page Rev. Date: 03-28-12

GM 4L60E 4WD HEX BOLT PATTERN TO JEEP NP231 T/C (27-SPLINES) UP TO 1994

KIT CONSISTS OF:

No.	Qty.	Part No.	Description
1.	1	51-0405	CASTING
2.	1	51-9111	CASTING
3.	1	716074	RELUCTORRING
4.	1	716079	PLUG
5.	1	716202	NP231 INPUT SHAFT
6.	1	*716325A	NEEDLE BEARING
7.	1	716511	"O"-RING
8.	1	716517	GASKET
9.	1	716757	SEAL
10.	1	716760	NP231 INPUT SEAL
11.	4	720011	10mm X 1.5 NUT
12.	4	720061	10mm-1.5 X 50mm STUD BOLTS
13.	1	300619	SENSOR

*INSTALLED AT ADVANCE ADAPTERS

OPTIONAL ITEMS:

It is possible to utilize the stock 700R-4 rubber mount by fabricating a plate to transfer the bolt pattern from our casting to your stock mount. If you are looking for another option we recommend our 716055 transmission mount. This mount is sold separately.



INSTALLATION INSTRUCTIONS:

This kit is designed to use a stock 4L60E 4x4 hex bolt pattern transmission to a New Process transfer case. If you do not have the 4x4 version of the 4L60E, you will have to purchase a new GM output shaft.

When installing the new transfer case adapter, make sure that the transfer case input sleeve and the output shaft do not bottom out. We have found on occasion that a transmission output shaft may be slightly longer than we have allowed for; and when coupling into the transfer case, we find a small amount of interference. The adapter housing and shaft must be assembled to the back of the transmission without interference. **DO NOT FORCE THE NEW TAILHOUSING ONTO THE TRANSMISSION.** If assistance is needed, please feel free to call us on our toll free number, **1-800 350-2223**.

When assembling the adapter housing to the transmission case, we have provided you with a new square type O-ring seal to prevent fluid leakage. This O-ring seal is a stock GM item.

This adapter can be used on either Jeep Wranglers 1987 & newer or Jeep Cherokees 1984 & newer. The only difference is the transfer case shifter linkage.

The adapter is 4.10" thick and will provide an overall transmission assembly length of 25-7/8".

SPECIAL NOTE: The components packaged in this kit have been assembled and machined for specific types of conversions. Modifications to any of the components will void any possible warranty or return privileges. If you do not fully understand the modifications or changes that will be required to complete your conversion, we strongly recommend that you contact our sales department for more information. This Instruction Sheet is only to be used for the assembly of Advance Adapter components. We recommend that a service manual pertaining to your vehicle be obtained for specific torque values, wiring diagrams and other related equipment. These manuals are normally available at automotive dealerships and parts stores.

ADVANCE ADAPTERS, INC.

P.O. Box 247, 4320 Aerotech Center Way
Paso Robles, CA 93447
Telephone: (800) 350-2223 Fax: (805) 238-4201

P/N: 50-0434

New Item: (01/07)
PAGE: 2 OF 4
Page Rev. Date: 03-14-08

GM 4L60E 4WD HEX BOLT PATTERN TO JEEP NP231 T/C (27-SPLINES) UP TO 1994

Jeep Wranglers 1987-96 will require shifter bracket Part No. 715523. Some applications will need to purchase a stock Jeep bracket, P/N 715545. This is the most universal for YJ Wranglers. TJ conversions will need bracket No.715542 to locate the complete linkage to the transmission and transfer case assembly.

THINGS TO CONSIDER BEFORE YOU BEGIN:

1. Medium strength thread locker is recommended on all threaded fasteners.
2. A sealant such as RTV (like the OEM sealant) is needed and is available from your local Jeep/Dodge dealer. P/N 82300234.

INSTRUCTIONS:

This new input gear will only fit the NP231 transfer cases. The installation of the gear will require the complete disassembly of your NP231 transfer case. Since the transfer case has to be completely disassembled, this is also a good time to install a short output shaft kit (fixed yoke kit) if you already have not done so.

If you've never disassembled a New Process transfer case, here are a couple of points to keep in mind that will make the installation much easier:

1. Keep all bolts, nuts, washers, etc. separated into groups as you remove them. Make sure you keep them in a labeled container that indicates what part of the transfer case they came from.
2. Keep all small parts in separate containers and label as to location and origin.
3. Make sure you have plenty of time and have a clean, spacious area to perform the installation.

Remove the front yoke nut with a 1-1/8" socket using an impact wrench. Remove the rear case bolts. A 10mm 12 pt. socket is needed for the spline head bolt and a 15mm socket for the remaining bolts. **NOTE:** The two black oxide finished bolts are located at the case dowel positions and require a washer under them. Start to remove the rear case from the front case by inserting pry bars at the cast-in locations **ONLY!** Pry apart evenly to break the sealer bead along the case mating surfaces. The front output shaft and chain should be retained with the rear portion of the case.



On the front side of the transfer case, you'll need to remove the 4 bolts that retain the aluminum bearing retainer. Once this is removed, you'll find a snap ring that retains the input gear to the cases' input bearing. This snap ring must be removed so that the input gear can be removed from the inside.



SPECIAL NOTE: The components packaged in this kit have been assembled and machined for specific types of conversions. Modifications to any of the components will void any possible warranty or return privileges. If you do not fully understand the modifications or changes that will be required to complete your conversion, we strongly recommend that you contact our sales department for more information. This Instruction Sheet is only to be used for the assembly of Advance Adapter components. We recommend that a service manual pertaining to your vehicle be obtained for specific torque values, wiring diagrams and other related equipment. These manuals are normally available at automotive dealerships and parts stores.

ADVANCE ADAPTERS, INC.

P. O. Box 247, 4320 Aerotech Center Way
Paso Robles, CA 93447
Telephone: (800) 350-2223 Fax: (805) 238-4201

P/N: 50-0434

New Item: (01/07)
PAGE: 3 OF 4
Page Rev. Date: 03-14-08

GM 4L60E 4WD HEX BOLT PATTERN TO JEEP NP231 T/C (27-SPLINES) UP TO 1994

On the inside of the transfer case, you'll now be able to remove the planetary assembly. Set the assembly on a work bench and locate the snap ring that retains the input gear into the planetary housing. Remove the snap ring and lift the input gear out of the planetary housing.



Once the input gear is removed, you'll find a thrust washer that must be reinstalled onto the new 27 spline input. When comparing the two input gears, they should look the same except for the internal splines. If you find a difference between the two. The NP231 transfer case used two styles of front input bearings. The early transfer case used a wide bearing and the later model used a narrow bearing. This new input gear is designed for only the early style case. New Process changed the bearing and gear pitch design in 1995. The center photo below show a later model input compared to a early.



Once you have verified that you have the same style input gear, install the gear into the planetary, install the snap ring. Re-install the planetary assembly into the case and secure the input to the bearing with the front snap ring. **Note:** The only part you should have left out of the case is the old input gear. During reassembly, make sure the oil return hole matches the front retainer hole.

TRANSMISSION INSTALLATION INFORMATION:

Before assembling, verify that the transmission has a 27 spline output shaft and the stickout is approximately 4.50". If shaft is longer, it may need to be shortened slightly to prevent bottoming out in the NP231 input shaft. Install the new reluctor ring with the set collar side going on the shaft first. Before tightening this clamp, trial fit the 51-0405 adapter plate onto the back of the 4L60E transmission. With the adapter set on the back of the transmission, install the 300619 reluctor sensor into the adapter casting. The 300619 sensor should line up over the teeth of the reluctor clamp. When you obtain this location, remove the adapter housing, making sure not to disturb the position of the clamp on the shaft. With the clamp now exposed, tighten the two set screws on the clamp.



SPECIAL NOTE: The components packaged in this kit have been assembled and machined for specific types of conversions. Modifications to any of the components will void any possible warranty or return privileges. If you do not fully understand the modifications or changes that will be required to complete your conversion, we strongly recommend that you contact our sales department for more information. This Instruction Sheet is only to be used for the assembly of Advance Adapter components. We recommend that a service manual pertaining to your vehicle be obtained for specific torque vales, wiring diagrams and other related equipment. These manuals are normally available at automotive dealerships and parts stores.

ADVANCE ADAPTERS, INC.

P. O. Box 247, 4320 Aerotech Center Way
Paso Robles, CA 93447
Telephone: (800) 350-2223 Fax: (805) 238-4201

P/N: 50-0434

New Item: (01/07)
PAGE: 4 of 4
Page Rev. Date: 03-28-12

GM 4L60E 4WD HEX BOLT PATTERN TO JEEP NP231 T/C (27-SPLINES) UP TO 1994

Loctite on these set screws is recommended.

Trial fit the 51-0405 adapter and 300619 sensor back on the transmission and make sure the reluctor ring teeth and sensor still line up properly. RTV Blue Silicone should be used to seal the 51-0405 adapter to your 4L60E transmission. Screw the 300619 sensor completely into the 51-0405 casting. With a feeler gauge, check the gap between the sensor and the reluctor ring. This gap should be around 0.010" to 0.012". Once 0.010" to 0.012" clearance is obtained, loctite the sensor into position.

Sensor note: This sensor will match up with the GM pigtail P/N 12162193 or Carquest P/N TX3A.

Once the 51-0405 is installed, install the 4 metric studs into the this adapter. Install the o-ring gasket on the 51-9111 adapter and bolt it to the 51-0405 casting. NOTE: The output shaft on the transmission should have a slight stick out past the adapter with the (51-9111) casting installed. The stock NP231 studs should be retained to install the transfer case to the new adapter kit. The casting has two rotations options.

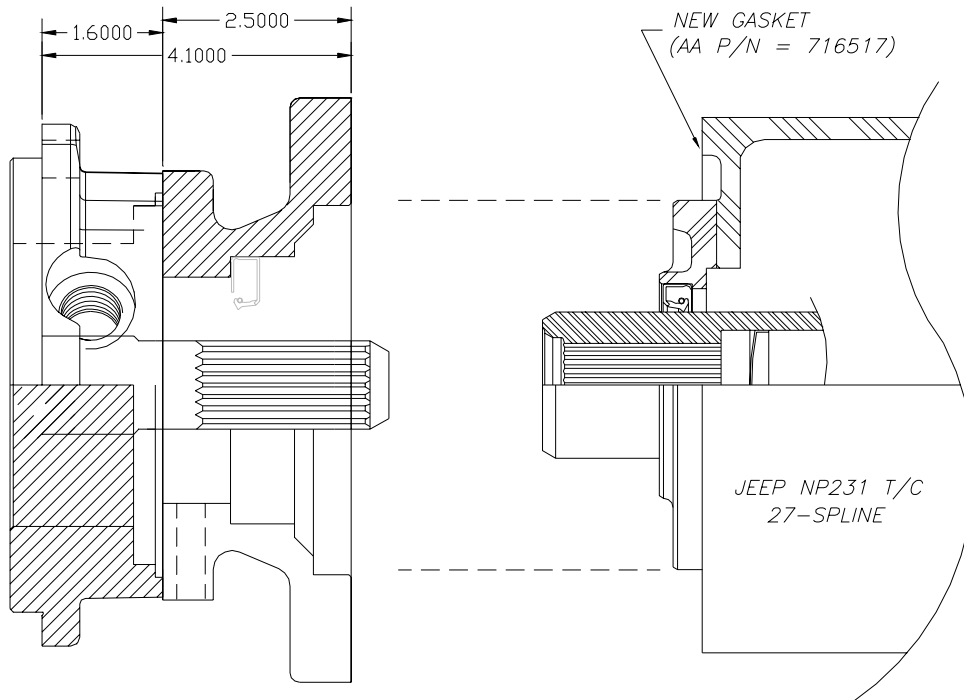

SPECIAL NOTE: The components packaged in this kit have been assembled and machined for specific types of conversions. Modifications to any of the components will void any possible warranty or return privileges. If you do not fully understand the modifications or changes that will be required to complete your conversion, we strongly recommend that you contact our sales department for more information. This Instruction Sheet is only to be used for the assembly of Advance Adapter components. We recommend that a service manual pertaining to your vehicle be obtained for specific torque values, wiring diagrams and other related equipment. These manuals are normally available at automotive dealerships and parts stores.